

M/T - Buzzing/Oil Canning Noises

TSB 08-2-10

02/04/08

4.6L MANUAL TRANSMISSION - SEPARATOR PLATE

BUZZ - BUILT BEFORE 12/13/2007

FORD:

2005-2008 Mustang

ISSUE

Some 2005-2008 Mustang vehicles built before 12/13/2007 and equipped with a 4.6L engine and manual transmission, may exhibit an oil-canning or exhaust rattle/buzz around 2000 - 2500 RPM during the first few minutes of driving after a cold start. The sound goes away after the car warms up.

ACTION

The concern may be caused by the separator plate, between the rear face of the block and the transmission housing, vibrating and/or contacting the flywheel. Follow the Service Procedure steps to correct the condition.

SERVICE PROCEDURE

1. Remove transmission per Workshop Manual (WSM), Section 308-03B.
2. Pry separator plate from rear face of block alignment dowels, slide out from between block and flywheel, and replace with new service part.
3. Install transmission per WSM, Section 308-03B.

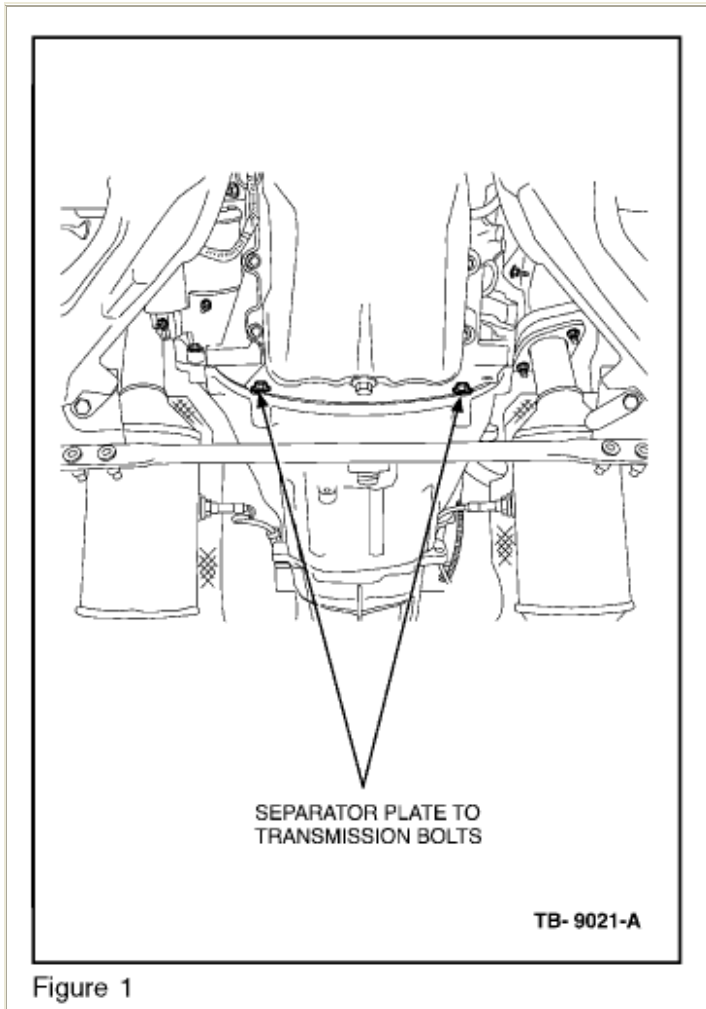

Figure 1

NOTE INSTALL NEW SEPARATOR PLATE TO TRANSMISSION BOLTS IF MISSING OR DAMAGED. (FIGURE 1)

PART NUMBER	PART NAME
8R3Z-7007-A W500231-S439	Separator Plate Bolt

Parts Block

WARRANTY STATUS: Eligible Under Provisions Of New Vehicle Limited Warranty Coverage

IMPORTANT : Warranty coverage limits/policies are not altered by a TSB. Warranty coverage limits are determined by the identified causal part.

OPERATION	DESCRIPTION	TIME
080210A	2005-2008 Mustang Built Before 12/13/2007: Replace Separator Plate, Includes Time To Remove	2.8 Hrs.

And Install Transmission
(Do Not Use With 7003A,
5212B, 4602A)

DEALER CODING

BASIC PART NO.	CONDITION CODE
6A373	07

NOTE: The information in Technical Service Bulletins is intended for use by trained, professional technicians with the knowledge, tools, and equipment to do the job properly and safely. It informs these technicians of conditions that may occur on some vehicles, or provides information that could assist in proper vehicle service. The procedures should not be performed by "do-it-yourselfers". Do not assume that a condition described affects your car or truck. Contact a Ford, Lincoln, or Mercury dealership to determine whether the Bulletin applies to your vehicle.