

TSB 07-16-7

08/20/07

EXTERIOR DOOR HANDLE NOT FLUSH IN THE CLOSED POSITION

FORD:

2005-2008 Mustang

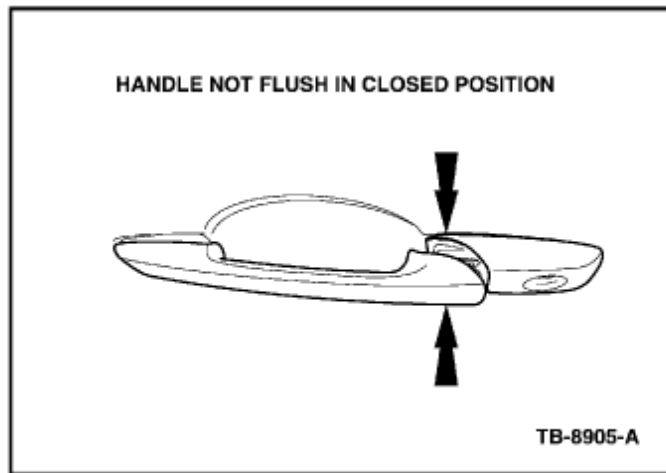

Figure 1

**ISSUE**

Some 2005-2008 Mustang vehicles may exhibit an exterior door handle not flush in the closed position. This may result in a loose handle, rattle noise, hard to open, and/or door self locks when opening outside handle. (Figure 1)

ACTION

The concern is caused by pre-loading/biasing the exterior door handle actuating rod, the front door latch, or both. Follow the Service Procedure steps to correct the condition.

SERVICE PROCEDURE

1. Raise the door window glass to the full up position.
2. Remove the door trim panel. Refer to Workshop Manual (WSM), Section 501-05.
3. Position the watershield aside.

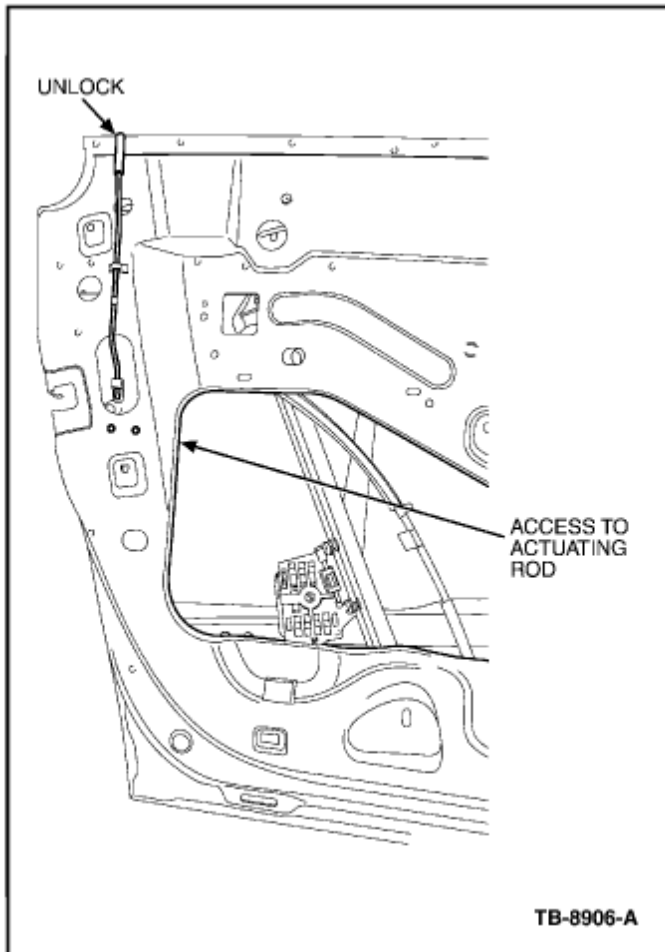

Figure 2



4. Raise the manual lock rod to the unlock position. (Figure 2)
5. Disconnect the exterior door handle actuating rod from the front door latch assembly.

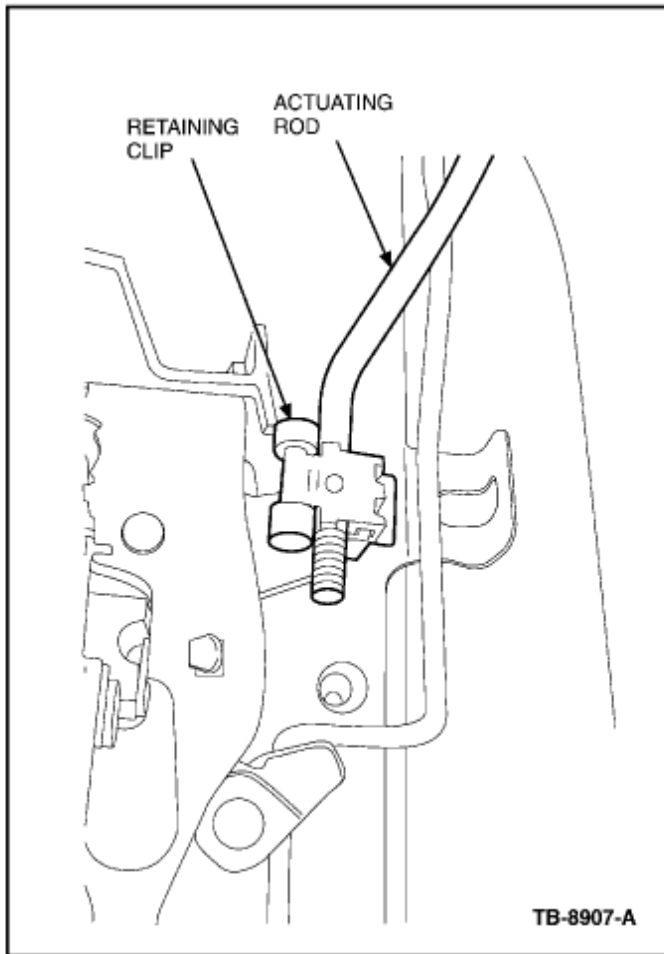

Figure 3



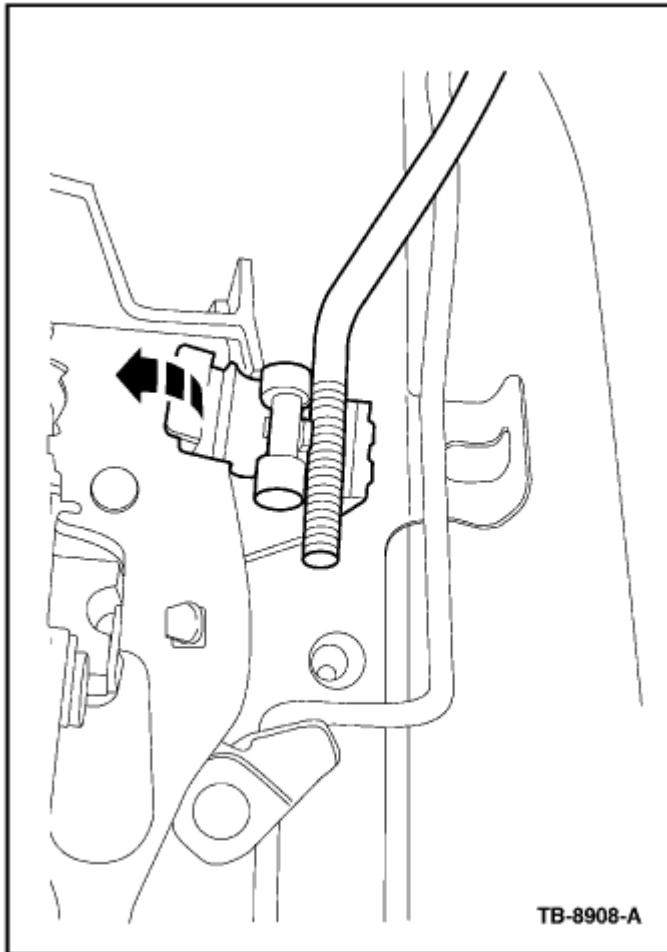

Figure 4

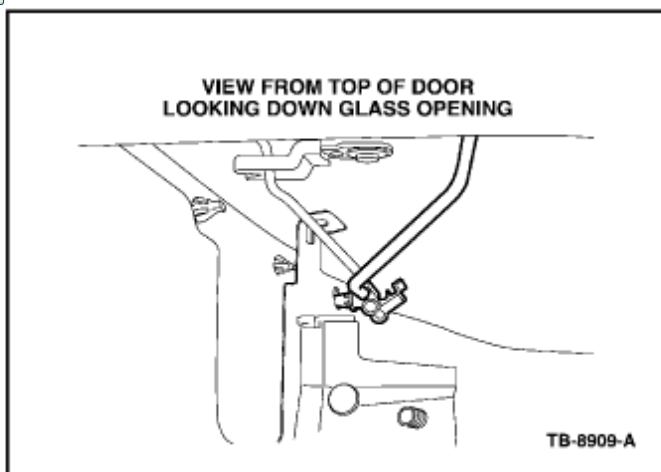

Figure 5

- a. Open the retaining clip and disconnect the actuating rod. (Figures 3 through 5)
6. Reinstall the exterior door handle actuating rod back into the clip.

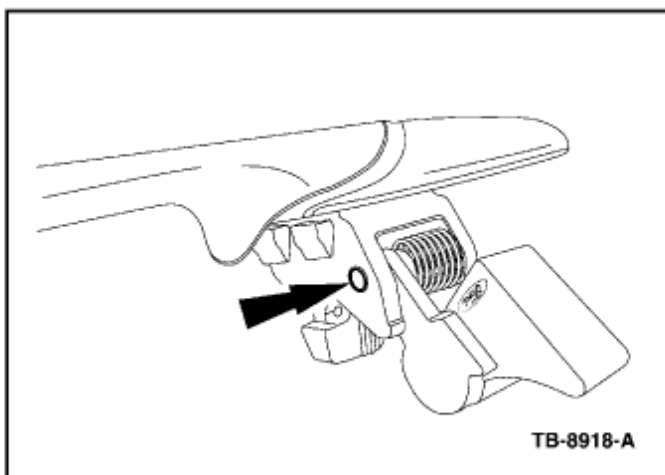

Figure 6



NOTE DO NOT PUSH PIN BACK INTO HANDLE. (FIGURE 6)

- a. Position the actuating rod into clip in a neutral or bias up position.
- b. Close the retaining clip and test the system to ensure that the exterior door handle is operating correctly.
- c. Adjust the actuating rod as necessary.

NOTE DO NOT BIAS THE ROD DOWN AND DO NOT BIAS THE FRONT DOOR LATCH.

NOTE IF EXTERIOR DOOR HANDLE IS BROKEN, OR THE METAL PIN IS PULLED OUT OF THE SPRING ON THE BACK OF THE DOOR HANDLE, THEN REPLACE THE DOOR HANDLE PER WSM, SECTION 501-14

- 7. Position back the watershield.
- 8. Install the door trim panel. Refer to WSM, Section 501-05.

WARRANTY STATUS: Eligible Under Provisions Of New Vehicle Limited Warranty Coverage

IMPORTANT : Warranty coverage limits/policies are not altered by a TSB. Warranty coverage limits are determined by the identified causal part.

OPERATION	DESCRIPTION	TIME
071607A	2005-2008 Mustang: Make Adjustments To The Door Handle Actuating Rod Following Procedure, Includes Time To Remove And Install Interior Door Panel: One Door (Do Not Use With 23943A)	0.5 Hr.
071607B	2005-2008 Mustang: Make Adjustments To The Door Handle Actuating Rod Following Procedure, Includes Time To Remove And Install Interior Door Panel: Both Doors (Do Not Use With 23943A)	0.8 Hr.

DEALER CODING

BASIC PART NO.	CONDITION CODE
7022152 OR 7022153	07

NOTE: The information in Technical Service Bulletins is intended for use by trained, professional technicians with the knowledge, tools, and equipment to do the job properly and safely. It informs these technicians of conditions that may occur on some vehicles, or provides information that could assist in proper vehicle service. The procedures should not be performed by "do-it-yourselfers". Do not assume that a condition described affects your car or truck. Contact a Ford, Lincoln, or Mercury dealership to determine whether the Bulletin applies to your vehicle.